

**PLASSON® KATALOG**



**SERIES 1**

**OBCHODNÍ KANCELÁŘ**

Tran - Sig - Ma, spol. s r.o.  
Dukelských hrdinů 747/19  
170 00 Praha - Holešovice

+420 233 373 040  
+420 233 370 903  
+420 233 310 676  
[info@tran-sig-ma.cz](mailto:info@tran-sig-ma.cz)

IČ: 0552810  
DIČ: CZ 0552810

**SKLAD PRAHA**

Tran - Sig - Ma, spol. s r.o.  
Výpadová 1608  
153 00 Praha - Radotín

+420 257 910 328  
+420 257 910 180  
[radotin@tran-sig-ma.cz](mailto:radotin@tran-sig-ma.cz)

**POBOČKA OLMOUC**

Tran - Sig - Ma, spol. s r.o.  
Pavelkova 2  
772 00 Olomouc

+420 585 312 381  
+420 585 312 925  
[olomouc@tran-sig-ma.cz](mailto:olomouc@tran-sig-ma.cz)

<b>1001</b> Spojka přímá		Page 7	<b>1001QQ</b> Spojka na PVC		Page 12
<b>17610</b> Univerzální opravná spojka		Page 7	<b>1001M</b> Spojka Metric to Imperial		Page 12
<b>17610/1761Q</b> Opravná spojka		Page 7	<b>1072</b> Spojka s vnějším mosazným závitem		Page 12
<b>1011</b> Spojka redukováná		Page 8	<b>1073</b> Spojka s vnitřním mosazným závitem		Page 13
<b>1012</b> Zátka		Page 8	<b>1073G</b> Spojka s vnitřním mosazným závitem G		Page 13
<b>1002</b> Spojka s vnějším závitem		Page 9	<b>1004</b> 90° T kus		Page 14
<b>1003</b> Spojka s vnitřním závitem		Page 9	<b>1034</b> 90° T kus redukováný		Page 14
<b>1003G</b> Spojka s vnitřním závitem G		Page 10	<b>1014</b> 90° T kus s vnitřním závitem		Page 15
<b>1001C</b> Spojka přímá -PE x CU		Page 10	<b>1005</b> 90° Koleno svěrné		Page 15
<b>1002C</b> Spojka s vnějším závitem - PE x CU		Page 10	<b>1006</b> 45° Koleno svěrné		Page 16
<b>1003C</b> Spojka s vnitřním závitem - PE X CU		Page 11	<b>1075</b> Nástěnka		Page 16
<b>10017</b> Univerzální spojka		Page 11	<b>1051</b> 90° Koleno redukováné		Page 17
<b>1001Q</b> PE na PVC spojka		Page 11	<b>1005M</b> 90° Koleno Metric to Imperial		Page 17

**1085** Page 17  
90° Koleno s vnějším závitem



**1015** Page 18  
90° Koleno s vnitřním závitem



**1077** Page 18  
90° Koleno s vnějším mosazným závitem



**1076** Page 19  
90° Koleno s vnitřním mosazným závitem



**03410** Page 19  
Ventil



**0341C** Page 19  
Ventil -PE x CU



**0358916** Page 20  
Matice pro vodoměr



**0358917** Page 20  
Matice se zpětnou klapkou



**10990** Page 20  
Klíč



**10004** Page 20  
Matka



**10002 / 10002C** Page 21  
O kroužek pro CU



**10002D** Page 21  
EPDM



**100029** Page 21  
Těsnění



**10003** Page 22  
Svěrný kroužek



**10008** Page 22  
Tlačný kroužek



**1099C** Page 22  
Podložka pro CU



**10008C** Page 23  
Kroužek pro CU



**1091Q** Page 23  
Sada pro spojky na PVC



**Spojka přímá**

**1001**

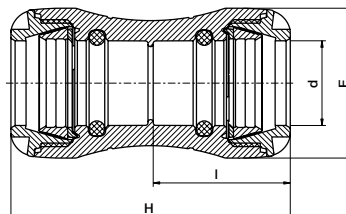

Product Code	Size d	E	H	I	UB	UC	W
100100020	20	41	92	45	1	260	64
100100025	25	47	98	48	1	200	80
100100032	32	58	108	53	1	120	126
100100040	40	70	142	70	1	90	256
100100050	50	85	158	78	1	55	369
100100063	63	103	183	90	1	30	620

**Univerzální opravná spojka**

**NEW!**

**17610**

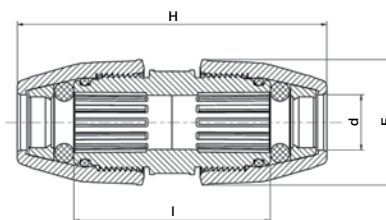

Product Code	Size d	E	H	I	UB	UC	W
176100024028	24-28	66	200	133	—	56	345
176100031035	31-35	76	210	143	—	40	—
176100040043	40-43	89	250	151	—	30	717
176100048051	48-51	101	270	158	—	20	—
176100060064	60-64	120	310	176	—	10	—

**Opravná spojka**

**17610/1761Q\***



Product Code	Size d x d	H	E	I	UB	UC	W
176100025	25	150	60	94	5	100	182
176100032	32	160	68	96	5	80	235

\* Split ring with metal teeth for wide range of plastic pipes

Spojka redukovaná

1011

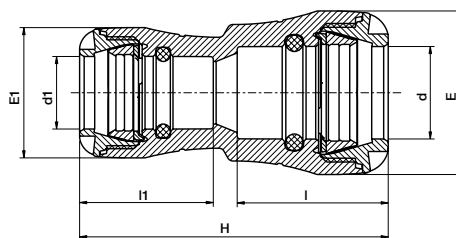

Product Code	Size d x d1	E	H	I	E1	l1	UB	UC	W
101100025020	25 x 20	47	100	48	41	45	1	200	75
101100032020	32 x 20	58	106	54	41	45	1	160	95
101100032025	32 x 25	58	110	54	47	48	1	160	109
101100040032	40 x 32	70	139	71	58	55	1	100	196
101100050025	50 x 25	85	151	79	47	46	1	80	262
101100050032	50 x 32	85	151	79	58	55	1	75	285
101100050040	50 x 40	85	165	77	58	53	1	65	326
101100063032	63 x 32	103	170	91	58	55	1	45	446
101100063040	63 x 40	103	184	91	70	72	1	40	485
101100063050	63 x 50	103	187	91	85	81	1	35	542

Zátka

1012

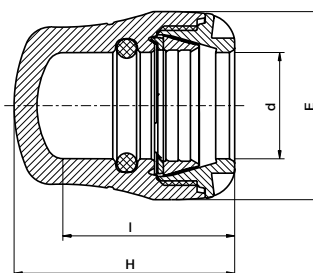

Product Code	Size d	E	H	I	UB	UC	W
101200020	20	41	56	45	1	360	39
101200025	25	47	60	48	1	300	50
101200032	32	58	68	53	1	220	82
101200040	40	70	90	71	1	150	146
101200050	50	85	102	79	1	100	229
101200063	63	103	117	91	1	55	379

**Spojka s vnějším závitem**

**1002**

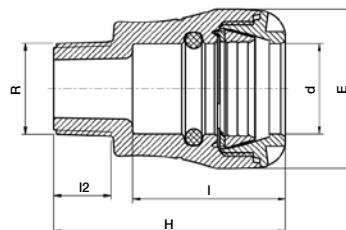

Product Code	Size d x R	E	H	I	I2	UB	UC	W
100200020005	20 x 1/2"	41	70	45	16	1	340	41
100200020007	20 x 3/4"	41	71	45	17	1	300	41
100200025005	25 x 1/2"	47	75	48	16	1	300	52
100200025007	25 x 3/4"	47	76	48	17	1	280	52
100200025010	25 x 1"	47	78	48	19	1	260	55
100200032007	32 x 3/4"	58	82	55	17	1	200	83
100200032010	32 x 1"	58	84	55	19	1	200	86
100200032013	32 x 1 1/4"	58	86	55	21	1	200	90
100200032015	32 x 1 1/2"	58	86	55	21	1	200	94
100200032020	32 x 2"	58	97	55	25	1	140	138
100200040010	40 x 1"	70	104	73	19	1	140	145
100200040013	40 x 1 1/4"	70	106	73	21	1	135	149
100200040015	40 x 1 1/2"	70	106	73	21	1	130	152
100200040020	40 x 2"	70	110	73	25	1	130	161
100200050010	50 x 1"	85	125	78	19	1	90	238
100200050013	50 x 1 1/4"	85	122	78	21	1	90	231
100200050015	50 x 1 1/2"	85	114	81	21	1	90	226
100200050020	50 x 2"	85	118	81	25	1	85	232
100200063015	63 x 1 1/2"	103	125	92	19	1	50	377
100200063020	63 x 2"	103	129	92	25	1	50	367

**Spojka s vnitřním závitem**

**1003**

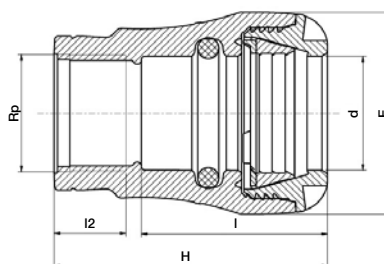

Product Code	Size d x Rp	E	H	I	I2	UB	UC	W
100300020005	20 x 1/2"	41	67	45	17	1	340	43
100300020007	20 x 3/4"	41	71	45	18	1	320	45
100300025005	25 x 1/2"	47	70	48	17	1	300	52
100300025007	25 x 3/4"	47	71	48	18	1	280	52
100300025010	25 x 1"	47	80	48	21	1	280	60
100300032007	32 x 3/4"	58	77	54	18	1	200	78
100300032010	32 x 1"	58	79	54	21	1	200	81
100300032013	32 x 1 1/4"	58	90	54	24	1	160	112
100300040010	40 x 1"	70	97	70	21	1	140	153
100300040013	40 x 1 1/4"	70	100	70	24	1	135	171
100300040015	40 x 1 1/2"	70	103	70	24	1	130	171
100300050013	50 x 1 1/4"	85	110	78	24	1	90	241
100300050015	50 x 1 1/2"	85	110	78	24	1	90	247
100300050020	50 x 2"	85	118	78	29	1	80	252
100300063015	63 x 1 1/2"	103	125	90	24	1	50	378
100300063020	63 x 2"	103	129	90	29	1	45	379

Spojka s vnitřním závitem G

1003G

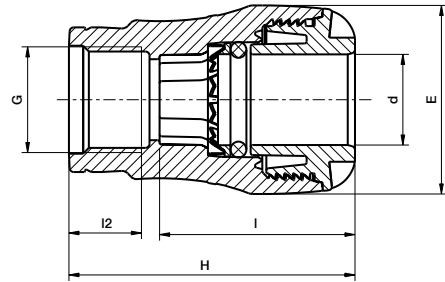

Product Code	Size d x G	H	E	I	I2	UB	UC	W
1003G0025007	25 x 3/4"	71	47	48	12	—	—	—
1003G0025010	25 x 1"	80	47	48	13.5	—	—	—
1003G0032007	32 x 3/4"	76	58	54	12	—	—	—
1003G0032010	32 x 1"	79	58	54	13.5	—	—	—

Spojka přímá - PE x CU

1001C

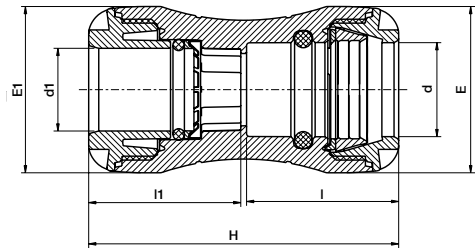

Product Code	Size d x d1	E	H	I	E1	l1	UB	UC	W
1001C0020015	20 x 15	41	92	45	41	45	1	260	68
1001C0025015	25 x 15	47	100	48	41	46	1	200	78
1001C0025022	25 x 22	47	98	48	47	48	1	180	81
1001C0032028	32 x 28	58	108	53	58	53	1	120	131
1001C0040028	40 x 28	70	139	71	58	55	1	120	203

Spojka s vnějším závitem - PE x CU

1002C

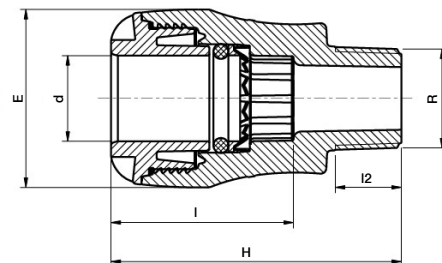

Product Code	Size d x R	E	H	I	I2	UB	UC	W
1002C7015007	15 x 3/4"	41	71	45	17	1	350	44
1002C7022007	22 x 3/4"	47	76	48	17	1	300	51
1002C7028010	28 x 1"	58	84	55	19	1	150	90

**Spojka s vnitřním závitem - PE x CU**

**1003C**

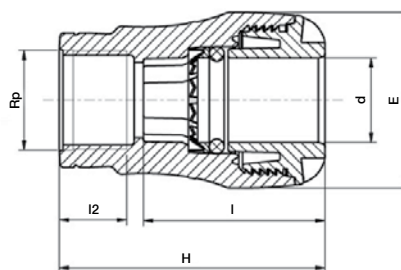

Product Code	Size d x Rp	H	E	I	I2	UB	UC	W
1003C7015007	15 x 3/4"	71	41	45	18	5	300	48
1003C7022007	22 x 3/4"	71	47	48	18	5	280	55

**Univerzální spojka**

**10017**

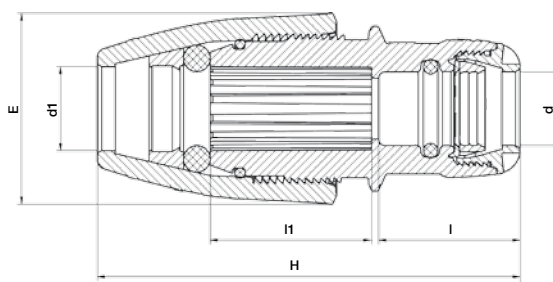

Product Code	Size d x d1	H	E	I	I1	UB	UC	W
100170025018	25 x 14-18	117-137	54	48	47	5	180	130
100170025022	25 x 19-22	119-130	57	48	47	5	150	141
100170025028	25 x 24-28	130-142	66	48	55	5	120	180

**PE na PVC spojka**

**1001Q**

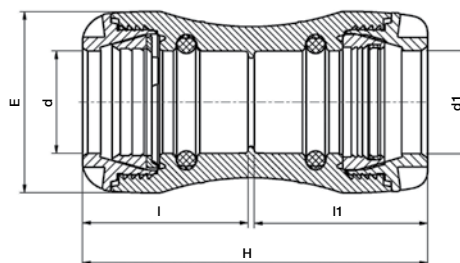

Product Code	Size d x d1*	H	E	I	I1	UB	UC	W
1001Q0025	25 x 25	100	47	48	50	1	160	85
1001Q0032	32 x 32	110	58	53	55	1	100	133
1001Q0040	40 x 40	145	70	70	73	1	100	249

\* d1-PVC connection



Spojka na PVC

1001QQ

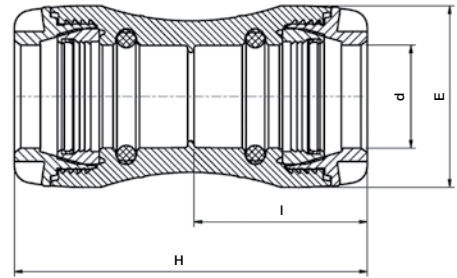

Product Code	Size d	H	E	I	UB	UC	W
1001QQ025	25	101	47	50	1	160	95
1001QQ032	32	112	70	55	1	100	144
1001QQ040	40	148	70	73	1	80	262

Spojka Metric na Imperial (IPS)

1001M

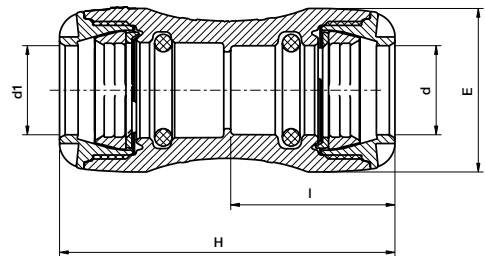

Product Code	Size d x d1	E	H	I	UB	UC	W
1001M6020005	20 x 1/2"	41	92	45	1	240	62
1001M6025005	25 x 1/2"	47	100	48	1	240	76
1001M6025007	25 x 3/4"	47	98	48	1	300	80
1001M6032010	32 x 1"	58	108	53	1	120	130

Spojka s vnějším mosazným závitem

1072

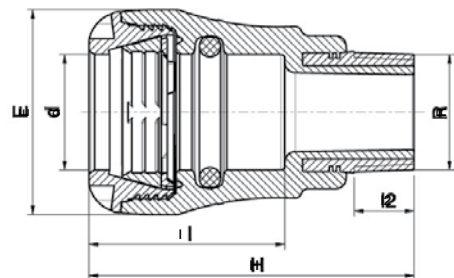

Product Code	Size d x R	E	H	I	l2	UB	UC	W
107200020005	20 x 1/2"	41	76	45	13	1	340	72
107200020007	20 x 3/4"	41	77	45	15	1	300	82
107200025005	25 x 1/2"	47	79	48	13	1	280	82
107200025007	25 x 3/4"	47	80	48	15	1	280	92
107200025010	25 x 1"	47	85	48	17	1	240	126
107200032007	32 x 3/4"	58	88	55	15	1	200	120
107200032010	32 x 1"	58	92	55	17	1	160	153
107200032013	32 x 1 1/4"	58	100	55	19	1	140	200
107200032015	32 x 1 1/2"	58	101	55	19	1	140	239
107200040010	40 x 1"	70	110	73	17	1	130	216
107200040013	40 x 1 1/4"	70	113	73	19	1	110	260
107200040015	40 x 1 1/2"	70	113	73	19	1	100	290
107200050010	50 x 1"	85	127	81	17	1	90	300
107200050013	50 x 1 1/4"	85	127	81	19	1	80	340
107200050015	50 x 1 1/2"	85	120	81	19	1	80	366
107200050020	50 x 2"	85	127	81	23	1	65	449
107200063015	63 x 1 1/2"	103	132	92	19	1	50	500
107200063020	63 x 2"	103	139	92	23	1	50	580

**Spojka s vnitřním mosazným závitem**

**1073**

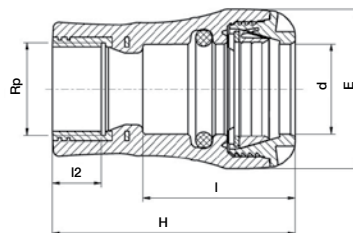

Product Code	Size d x Rp	E	H	I	I2	UB	UC	W
107300020005	20 x 1/2"	41	73	45	15	1	300	80
107300020007	20 x 3/4"	41	80	45	16	1	280	100
107300025005	25 x 1/2"	47	76	48	15	1	280	91
107300025007	25 x 3/4"	47	78	48	16	1	280	104
107300025010	25 x 1"	47	89	48	19	1	200	136
107300032007	32 x 3/4"	58	86	56	16	1	180	131
107300032010	32 x 1"	58	88	56	19	1	160	156
107300032013	32 x 1 1/4"	58	98	56	21	1	120	214
107300040007	40 x 3/4"	70	109	73	16	1	130	196
107300040010	40 x 1"	70	106	73	19	1	130	226
107300040013	40 x 1 1/4"	70	109	73	21	1	110	273
107300040015	40 x 1 1/2"	70	113	73	21	1	100	299
107300050010	50 x 1"	85	113	81	19	1	80	313
107300050013	50 x 1 1/4"	85	124	81	21	1	80	350
107300050015	50 x 1 1/2"	85	118	81	21	1	80	367
107300050020	50 x 2"	85	127	81	26	1	65	457
107300063015	63 x 1 1/2"	103	128	92	21	1	50	515
107300063020	63 x 2"	103	133	92	26	1	50	586

**Spojka s vnitřním mosazným závitem**

**1073G**

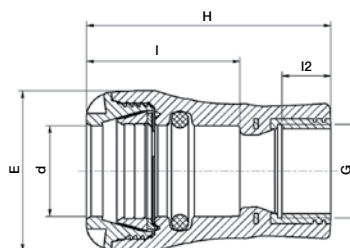

Product Code	Size d x G	H	E	I	I2	UB	UC	W
1073G0025007	25 x 3/4"	78	47	48	12	1	240	98
1073G0025010	25 x 1"	89	47	48	14	1	200	136
1073G0032007	32 x 3/4"	86	58	56	12	1	200	135
1073G0032010	32 x 1"	88	58	56	14	1	160	155
1073G0040013	40 x 1 1/4"	109	70	73	19	1	110	262

\* For connecting parallel male thread

90° T kus

1004

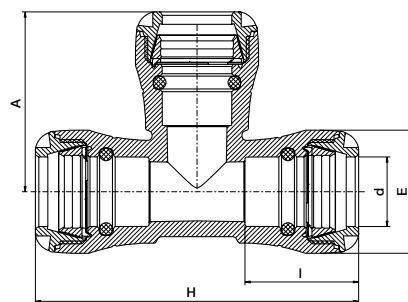

Product Code	Size d	E	H	A	I	UB	UC	W
100400020	20	41	123	71	45	1	140	103
100400025	25	47	134	78	48	1	100	137
100400032	32	58	152	84	54	1	60	221
100400040	40	70	192	108	70	1	45	429
100400050	50	85	214	124	78	1	30	667
100400063	63	103	262	147	90	1	14	1157

90° T kus redukovaný

1034

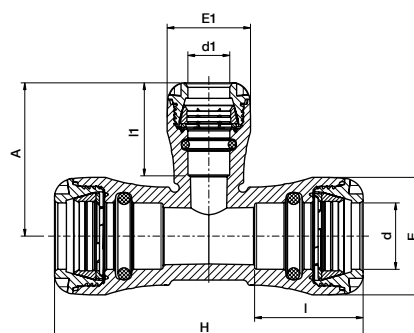

Product Code	Size d x d1 x d	H	A	E	E1	I	l1	UB	UC	W
103400025020	25 x 20 x 25	134	73	47	41	48	46	1	120	127
103400032020	32 x 20 x 32	152	75	58	41	54	46	1	80	185
103400032025	32 x 25 x 32	152	81	58	47	54	49	1	80	195
103400040025	40 x 25 x 40	192	86	70	47	70	49	1	55	325
103400040032	40 x 32 x 40	192	93	70	58	70	54	1	55	356
103400050025	50 x 25 x 50	214	90	85	47	78	49	1	35	500
103400050032	50 x 32 x 50	214	98	85	58	78	54	1	35	530
103400063025	63 x 25 x 63	262	96	103	47	90	49	1	24	848
103400063032	63 x 32 x 63	262	100	103	58	90	54	1	20	871

**90° T kus s vnitřním závitem**

**1014**

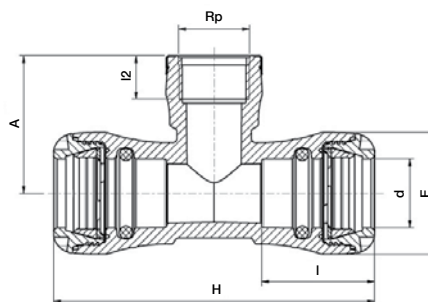

Product Code	Size d x Rp	E	H	A	I	l2	UB	UC	W
101400020005	20 x 1/2"	41	123	43	45	17	1	200	84
101400020007	20 x 3/4"	41	123	46	45	18	1	180	88
101400020010	20 x 1"	41	123	52	45	21	1	180	99
101400025005	25 x 1/2"	47	134	46	48	17	1	140	105
101400025007	25 x 3/4"	47	134	46	48	18	1	140	107
101400025010	25 x 1"	47	134	54	48	21	1	140	114
101400032007	32 x 3/4"	58	152	52	54	18	1	80	172
101400032010	32 x 1"	58	152	55	54	21	1	80	183
101400032013	32 x 1 1/4"	58	152	63	54	24	1	60	215

**90° Koleno svěrné**

**1005**

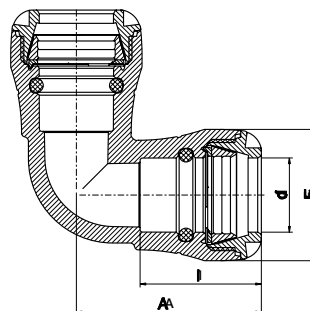

Product Code	Size d	E	A	I	UB	UC	W
100500020	20	41	67	45	5	200	75
100500025	25	47	73	48	5	160	96
100500032	32	58	81	54	5	100	157
100500040	40	70	106	70	1	65	291
100500050	50	85	119	78	1	40	462
100500063	63	103	141	90	1	25	799

45° Koleno svěrné

1006

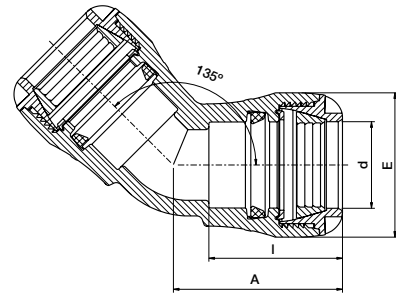

Product Code	Size d	E	I	A	UB	UC	W
100600032	32	58	54	67	5	120	147
100600040	40	70	71	88	—	80	263
100600050	50	85	79	100	—	40	428
100600063	63	103	90	118	1	25	719

Nástěnka

1075

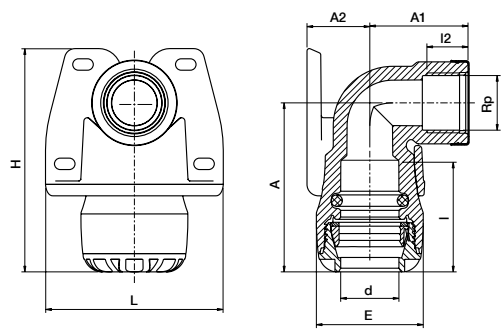

Product Code	Size d x Rp	E	I	I2	A	A1	A2	L	H	UB	UC	W
107500020005	20 x 1/2"	41	45	17	67	39	28	73	95	5	160	92
107500020007	20 x 3/4"	41	45	18	67	43	28	73	95	5	160	96
107500025005	25 x 1/2"	47	48	17	74	40	28	78	98	5	140	110
107500025007	25 x 3/4"	47	48	18	74	43	28	78	98	5	140	116

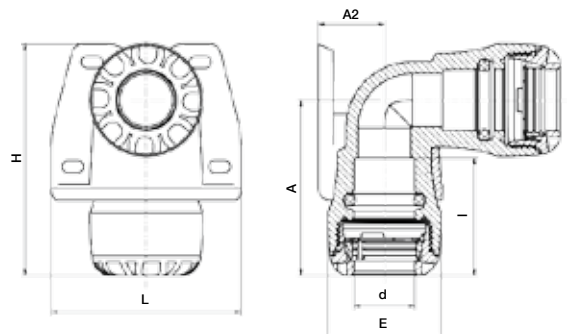

Product Code	Size d x d	E	I	A	A2	L	H	UB	UC	W
107500025	25 x 25	47	48	74	28	78	98	5	125	138

**90° Koleno redukované**

**1051**

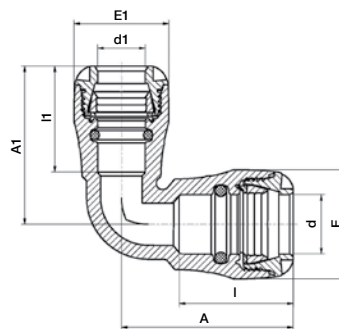

Product Code	Size d x d1	A	E	I	A1	E1	I1	UB	UC	W
105100025020	25 x 20	74	47	48	68	41	46	5	160	90

**90° Koleno Metric na Imperial (IPS)**

**1005M**

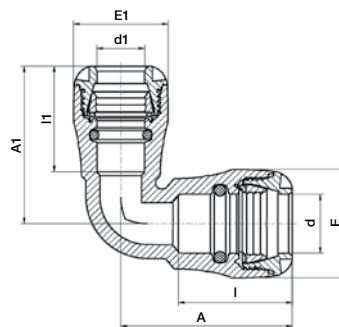

Product Code	Size d x d1	A	E	I	A1	E1	I1	UB	UC	W
1005M6025005	25 x 1/2"	74	47	48	68	41	46	5	180	89
1005M6025007	25 x 3/4"	73	47	48	73	47	48	5	160	101

**90° Koleno s vnějším závitem**

**1085**

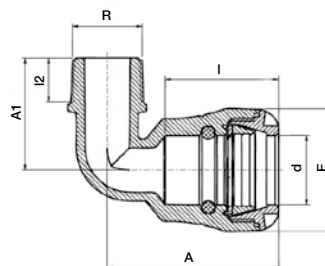

Product Code	Size d x R	E	A	I	A1	I2	UB	UC	W
108500020005	20 x 1/2"	41	66	45	41	16	5	300	47
108500020007	20 x 3/4"	41	66	45	42	17	5	300	52
108500025005	25 x 1/2"	47	74	48	44	16	5	290	57
108500025007	25 x 3/4"	47	74	48	45	17	5	250	64
108500025010	25 x 1"	47	74	48	47	19	5	220	65
108500032007	32 x 3/4"	58	81	53	51	17	5	190	90
108500032010	32 x 1"	58	81	53	53	19	5	180	92
108500032013	32 x 1 1/4"	58	81	53	54	21	5	150	114
108500040010	40 x 1"	70	107	71	57	19	1	110	173
108500040013	40 x 1 1/4"	70	107	71	58	21	1	100	189
108500040015	40 x 1 1/2"	70	107	71	60	21	1	100	194
108500050013	50 x 1 1/4"	85	122	79	68	22	1	60	275
108500050015	50 x 1 1/2"	85	122	79	68	21	1	65	290
108500063013	63 x 1 1/4"	103	143	90	76	22	1	40	445
108500063015	63 x 1 1/2"	103	143	90	78	21	1	40	458
108500063020	63 x 2"	103	143	90	81	25	1	40	492

90° Koleno s vnitřním závitem

1015

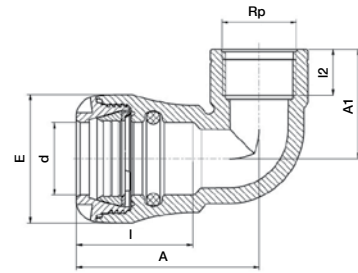

Product Code	Size d x Rp	E	I	A	A1	l2	UB	UC	W
101500020005	20 x 1/2"	41	45	67	39	17	5	240	51
101500020007	20 x 3/4"	41	45	67	43	18	5	240	55
101500020010	20 x 1"	41	45	67	49	21	5	240	64
101500025005	25 x 1/2"	47	48	74	40	17	5	220	63
101500025007	25 x 3/4"	47	48	74	43	18	5	200	70
101500025010	25 x 1"	47	48	74	50	21	5	180	82
101500032007	32 x 3/4"	58	54	83	45	18	5	180	95
101500032010	32 x 1"	58	54	83	49	21	5	160	111
101500032013	32 x 1 1/4"	58	54	83	60	24	5	120	145
101500040010	40 x 1"	70	72	107	51	21	1	110	179
101500040013	40 x 1 1/4"	70	72	107	61	24	1	100	226
101500040015	40 x 1 1/2"	70	72	107	65	24	1	90	244
101500050015	50 x 1 1/2"	85	79	119	63	24	1	60	330
101500050020	50 x 2"	85	79	119	75	29	1	55	349
101500063020	63 x 2"	103	79	141	70	29	1	35	534

90° Koleno s vnějším mosazným závitem

1077

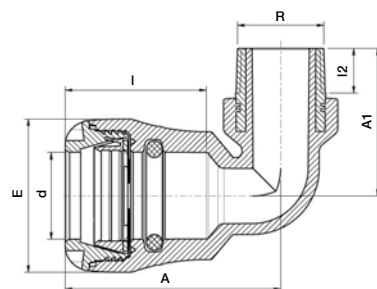

Product Code	Size d x R	E	I	A	A1	l2	UB	UC	W
107700032007	32 x 3/4"	58	53	81	80	15	5	120	239
107700032010	32 x 1"	58	53	81	83	17	5	120	172
107700032013	32 x 1 1/4"	58	53	81	83	19	5	120	284
107700032015	32 x 1 1/2"	58	53	81	83	19	5	120	305
107700040010	40 x 1"	70	59	104	71	17	1	90	239
107700040013	40 x 1 1/4"	70	59	104	71	19	1	90	295
107700040015	40 x 1 1/2"	70	59	104	71	19	1	85	341
107700050010	50 x 1"	85	79	116	62	19	1	70	337
107700050013	50 x 1 1/4"	85	79	116	68	21	1	70	384
107700050015	50 x 1 1/2"	85	79	116	73	21	1	50	431
107700050020	50 x 2"	85	79	116	85	23	1	50	549
107700063013	63 x 1 1/4"	103	90	134	74	21	1	30	559
107700063015	63 x 1 1/2"	103	90	134	74	21	1	40	588
107700063020	63 x 2"	103	90	134	85	26	1	40	726

**90° Koleno s vnitřním mosazným závitem**

**1076**

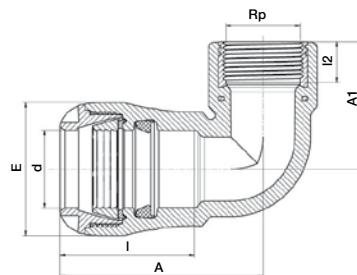

Product Code	Size d x Rp	E	I	A	A1	l2	UB	UC	W
107600032010	32 x 1"	58	53	73	60	19	1	140	187
107600040007	40 x 3/4"	70	72	107	51	16	1	120	219
107600040010	40 x 1"	70	72	107	60	19	1	90	252
107600040013	40 x 1 1/4"	70	72	107	67	21	1	90	313
107600040015	40 x 1 1/2"	70	72	107	70	21	1	85	355
107600050010	50 x 1"	85	79	122	60	19	1	70	349
107600050013	50 x 1 1/4"	85	79	122	67	21	1	60	403
107600050015	50 x 1 1/2"	85	79	122	73	21	1	60	455
107600050020	50 x 2"	85	79	122	84	26	1	50	558
107600063013	63 x 1 1/4"	103	90	143	68	21	1	40	575
107600063015	63 x 1 1/2"	103	90	143	72	21	1	40	621
107600063020	63 x 2"	103	90	143	82	26	1	40	747

**Ventil**

**03410**

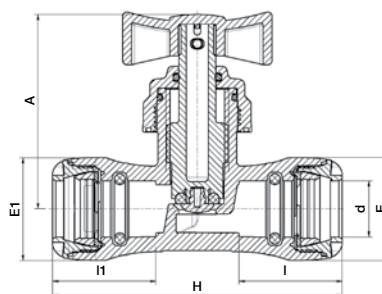

Product Code	Size d x d	H	A	E	I	E1	I1	UB	UC	W
034100020	20 x 20	123	89	41	45	—	—	1	100	145
034100025	25 x 25	134	89	47	48	—	—	1	100	167
034100025020	25 x 20	129	89	47	48	42	45	1	100	161
034100032	32 x 32	152	89	58	54	—	—	1	80	225

**Ventil - PE x CU**

**0341C**

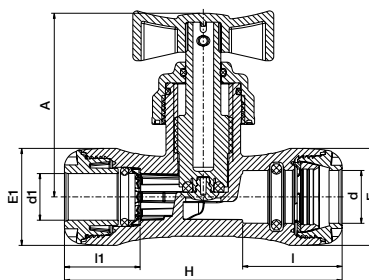

Product Code	Size d x d1	H	A	E	E1	I	I1	UB	UC	W
0341C0020015	20 x 15	123	89	41	41	45	45	1	100	149
0341C0025015	25 x 15	129	89	47	42	48	46	1	100	165
0341C0025022	25 x 22	134	89	47	47	48	48	1	100	171
0341C0032028	32 x 28	159	89	58	58	54	54	1	80	223



Matice pro vodoměr

0358916

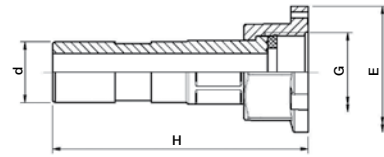

Product Code	Size d x G	E	H	UB	UC	W
0358916020	20 x 3/4"	44	86	1	150	37
0358916025	25 x 1"	50	90	1	150	53

10990005 wrench for brass threaded elbows

Matice se zpětnou klapkou

0358917

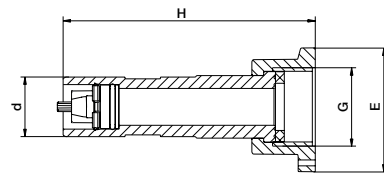

Product Code	Size d x G	E	H	UB	UC	W
—	20 x 3/4"	44	86	1	150	37
—	25 x 1"	50	90	1	150	53

10990005 wrench for brass threaded elbows

Klíč

10990



Product Code	Size	UB	UC	W
10990004	20 - 32	1	300	72
10990002	40 - 63	1	100	285

Matka

10004

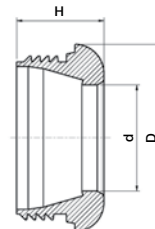

Product Code	Size d	D	H	UB	UC	W
100040020P	20	40	22	50	700	7
100040025P	25	45	22	50	500	8
100040032P	32	57	24	50	300	15
100040040P	40	68	33	—	400	29
100040050P	50	83	37	—	125	44
100040063P	63	100	43	—	100	60

**O kroužek pro CU**

**10002 / 10002C\***



Product Code	Pipe Size	E	e	UB	UC	W
10002C015P	15"	13.6	4	50	32000	1
100020020P	20	19	4	50	32000	1
10002C022P	22"	20.6	4.1	50	16000	1
100020025P	25	24	5	50	16000	2
10002C028P	28"	26.8	3.9	50	10000	1
100020032P	32	31	6	50	10000	4

**EPDM**

**10002D**



Product Code	Pipe Size	E	e	UB	UC	W
10002D020P	20	19	4	50	32000	1
10002D025P	25	24	5	50	16000	2
10002D032P	32	31	6	50	10000	4

**Těsnění**

**100029**



Product Code	Pipe Size	E	e	UB	UC	W
100029040P	40	38	10	50	4000	8
100029050P	50	48.6	10.5	50	2500	11
100029063P	63	60.6	11.2	50	2000	15

Svěrný kroužek

10003

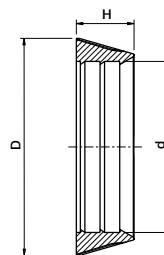

Product Code	Size d	D	H	UB	UC	W
100030020P	20	27	9	50	6000	2
100030025P	25	33	9	50	4500	3
100030032P	32	42	11	50	2000	4
100030040P	40	52	14	—	1600	14
100030050P	50	64	17	—	500	14
100030063P	63	81	21	—	500	27

Tlačný kroužek

10008

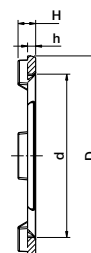

Product Code	Size d	D	H	h	UB	UC	W
100080020P	20	27	3.8	1.8	50	7000	1
100080025P	25	33	3.7	1.7	50	5500	1
100080032P	32	42	3.7	1.7	50	3000	1
100080040P	40	52	4.0	2.2	50	2500	2
100080050P	50	64	4.3	2.5	50	1000	3
100080063P	63	80	4.8	3.0	50	1000	6

Podložka pro CU

1099C



Product Code	Size d	D	H	UB	UC	W
1099C015P	15	21	2.7	50	—	0.4
1099C022P	22	28	3	50	—	0.4
1099C021P	21	34	3	50	—	1
1099C028P	28	34	2	50	—	1

**Kroužek pro CU**

**10008C**

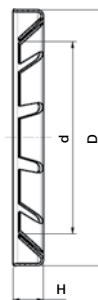

Product Code	Size d	D	H	UB	UC	W
10008C015P	15	21	1.9	50	6000	1
10008C022P	22	28	2.0	50	5000	1
10008C021P	21	34	2.2	50	3000	1
10008C028P	28	34	2.2	50	3000	1

**Sada pro spojky na PVC**

**1091Q**

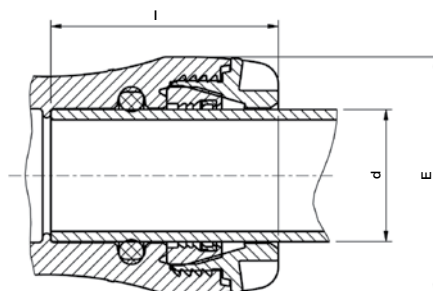

Product Code	Size d	E	I	UB	UC	W
1091Q0025	25	47	50	1	500	26
1091Q0032	32	58	55	1	400	31
1091Q0040	40	70	72	1	300	56